

All-New Hyundai NEXO

The Future Utility Vehicle made by Hyundai

Hyundai 2019 - 02
Kaat Van Severen
Fleet & Remarketing Manager

**40 years
in Europe
more than
7.5 million cars**



87%
sales growth
in 10 years



#1 Asian Brand
By 2020



Pioneering in electrification



 **HYUNDAI**

2020 Sustainability Strategy



15
CARS
GLOBALLY



Hybrid Electric
Vehicle



Plug-in Hybrid
Electric Vehicle



Electric
Vehicle



Fuel Cell
Vehicle



Europe 2020



10 eco cars



of Hyundai's
line up



IONIQ: World's first car with three electrified powertrains



 **HYUNDAI**

 HYUNDAI

FuelCell



AIR LIQUIDE

GLOBAL LEADER
in FuelCell technology

 HYUNDAI

Pioneer

R&D Fuel Cell Technology and applications



Hyundai ECCOV

Hybride elektrische driewieler
2011

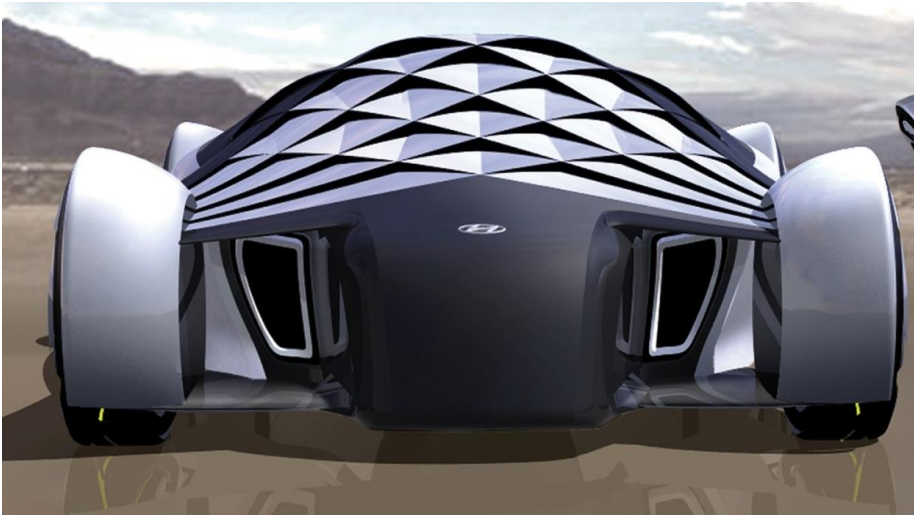

Hyundai Black Fish

Fuel Cell motor in each wheel
2009



Hyundai SBSS

(self balanced single seater)
2009



Hyundai Red Hawk

Airplanes on Fuel Cell
2009

Hyundai Vision GT

2 Fuel Cells, together 884 hp

2015





Intrado - SUV Concept

+600 km driving range

2014

H350 FCEV

Minibus / Van

136 hp - 150 km/h

422 km driving range

2016



Fuel Cell Development

Hyundai's journey to leadership





Eerste in serie geproduceerde waterstofauto

De Hyundai ix35 FCEV is in 2013 de eerste in serie geproduceerde auto met brandstofcel

Meest verkochte waterstofauto

Sinds 2017 zijn er maar liefst 500 Hyundai-waterstofauto's geregistreerd in Europa, meer dan alle andere merken bij elkaar. Hyundai verkoopt elektrische auto's met een brandstofcel in 18 landen, waarvan 13 in Europa.



Continue aandacht voor het milieu

Hyundai focust zich sinds 1998 nadrukkelijk op de ontwikkeling van elektrische auto's met brandstofcel en doet er alles aan om zijn rol als wereldleider op het gebied van milieuvriendelijke technologie zo goed mogelijk te vervullen.



WORLDS 1ST FUEL CELL CAR SHARING FLEET IN MUNICH



WORLDS 1ST FUEL CELL TAXI FLEET IN PARIS

 HYUNDAI





Benzine? Diesel? Neen, waterstof.

Jonas vertelt: "We testen sinds 2015 de Hyundai ix35, de eerste in serie gemaakte waterstofwagen. Onze auto was meteen ook de eerste in België. We onderzoeken de mogelijkheden van waterstof als brandstof voor voertuigen."

Hoe zo'n waterstofwagen precies werkt? "De brandstofcel aan boord zet waterstof om naar elektriciteit. Die elektriciteit drijft de motor aan en zorgt er dus voor dat de auto rijdt. Uit de uitlaat van een waterstofwagen komt **alleen waterdamp**." Daarom kan waterstof de oplossing zijn voor heel wat milieuproblemen. De voorwaarde is dan wel dat de waterstof op een duurzame manier geproduceerd wordt.



Wie weet rijden al onze firmawagens over enkele jaren wel op waterstof.



NEXO



**CREATED FOR EFFICIENCY.
DESIGNED FOR BEAUTY.**

12.3" Wide Screen

Exquisite bio-materials





Hyundai SmartSense™1.

Hyundai SmartSense™1 features 6 technologies to assist in alerting you to avoid any dangers around you whilst on the road. Some of these include Blind-Spot Collision Warning (BCW), Lane Keeping Assist (LKA) and Driver Attention Warning (DAW).



Advanced Driver Assistance Systems
LFA(Lane Following Assist)

Since there have been no relevant legal system in many countries, we need to apply new ADAS technology gradually, step by step depending on region.



Advanced Driver Assistance Systems
BVM (Blind-spot View Monitor)

Since there have been no relevant legal system in many countries, we need to apply new ADAS technology gradually, step by step depending on region.

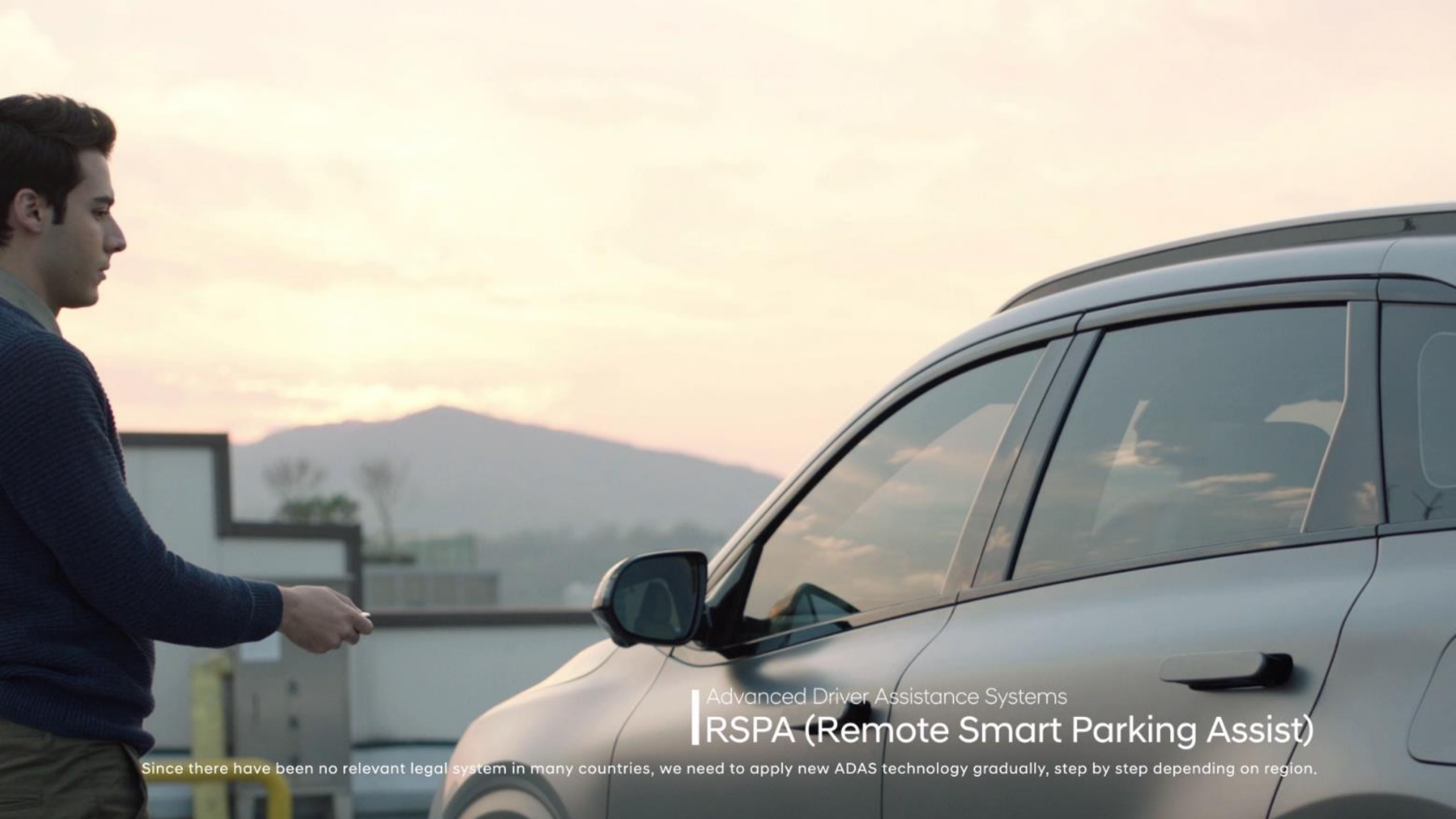

Advanced Driver Assistance Systems
RSPA (Remote Smart Parking Assist)

Since there have been no relevant legal system in many countries, we need to apply new ADAS technology gradually, step by step depending on region.

HOW DOES FUEL CELL WORK?

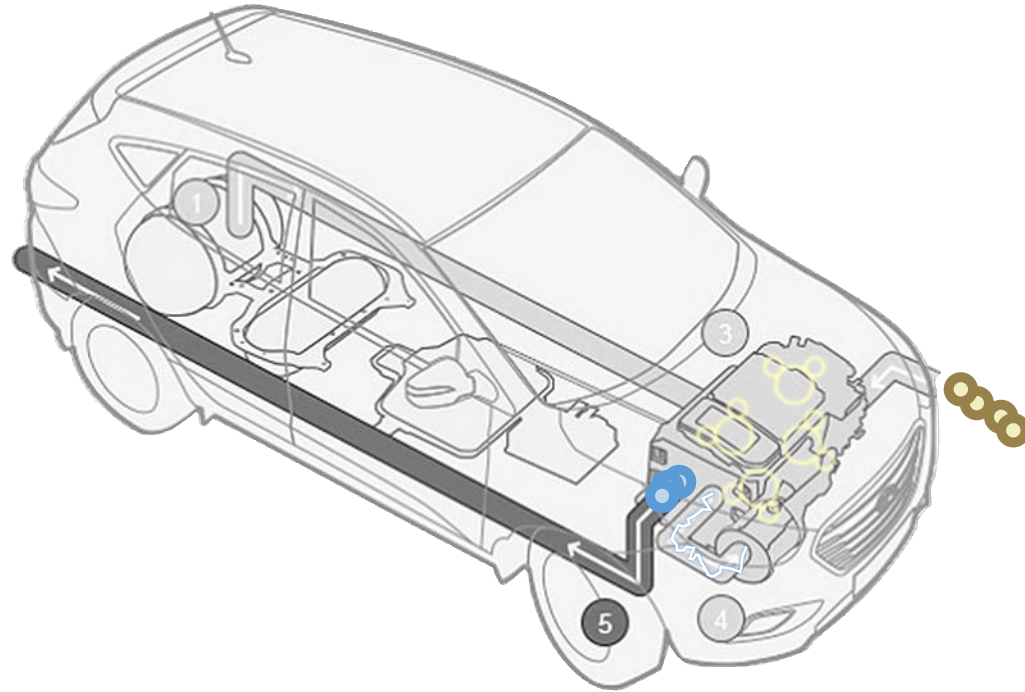

Zero Emissions
Reverse osmosis
(Water supply)
(Water supply)

Hyundai NEXO cleans over 900kg of air during clean driving month





Hyundai. Het enige merk dat u standaard
5 jaar waarborg zónder kilometerbeperking aanbiedt.

