



Hydrogen Expertise at OCAS

VSWB-meeting

29 September 2010

OCAS : a joint venture between ArcelorMittal and the Flemish Region



Hydrogen research at OCAS

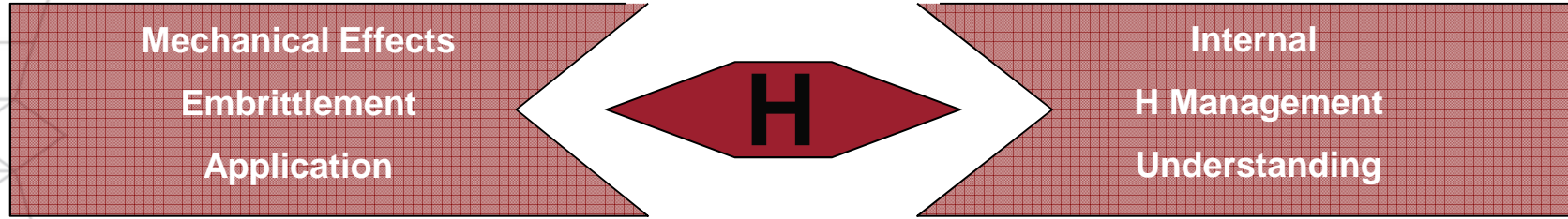

Constant Load

Incremental Step Loading

Disc Rupture Test
Gaseous H₂



Tensile
Charpy



How much?



Where?



How fast?

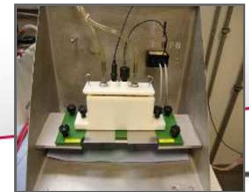

Upcoming: HIC/SSCC laboratory

© 2007 – OCAS – All rights reserved for all countries
 Cannot be disclosed, used, or reproduced without prior written specific authorization of OCAS
 CONFIDENTIAL – Privileged Information – OCAS' proprietary information

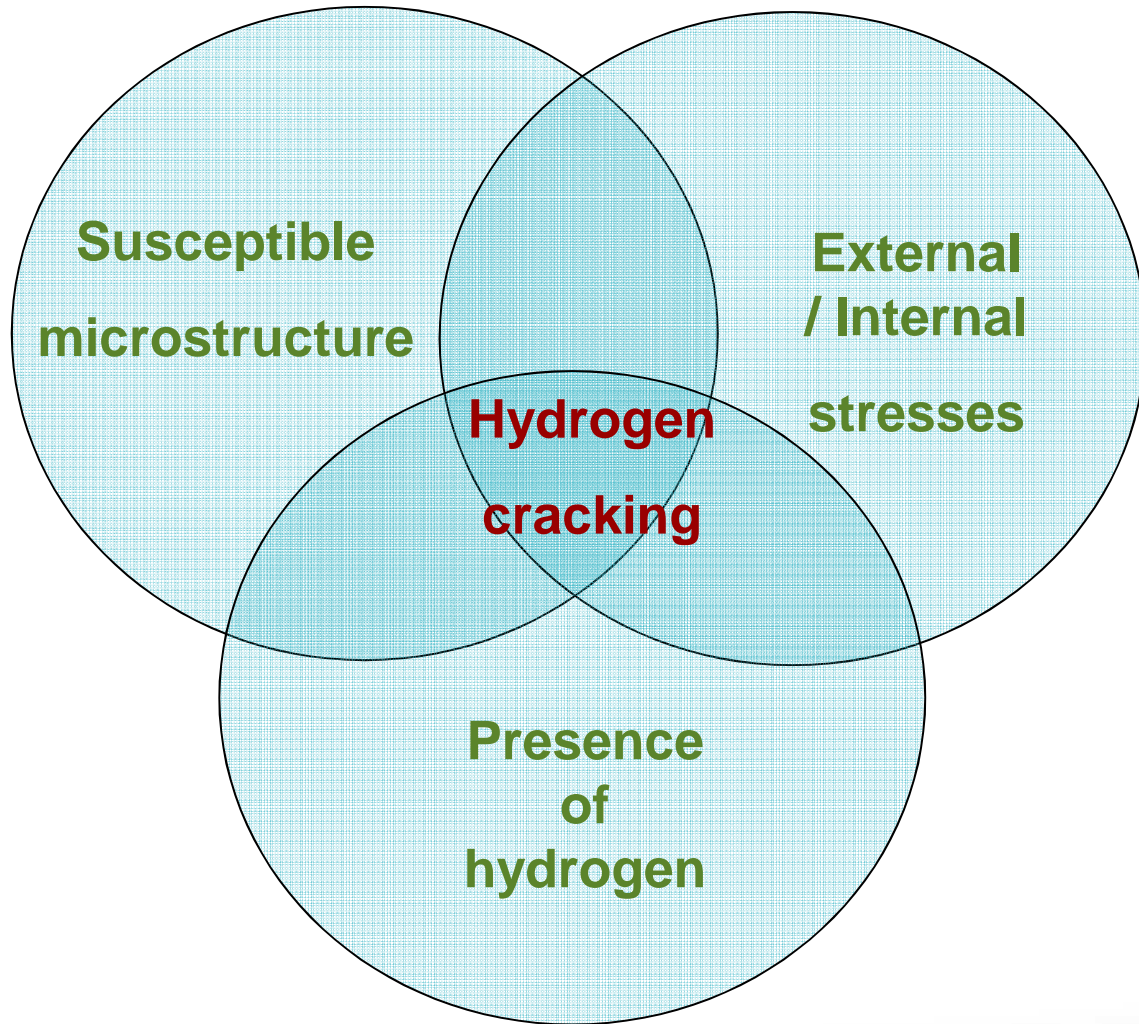

© 2007 – OCAS – All rights reserved for all countries
Cannot be disclosed, used, or reproduced without prior written specific authorization of OCAS
CONFIDENTIAL – Privileged Information – OCAS' proprietary information

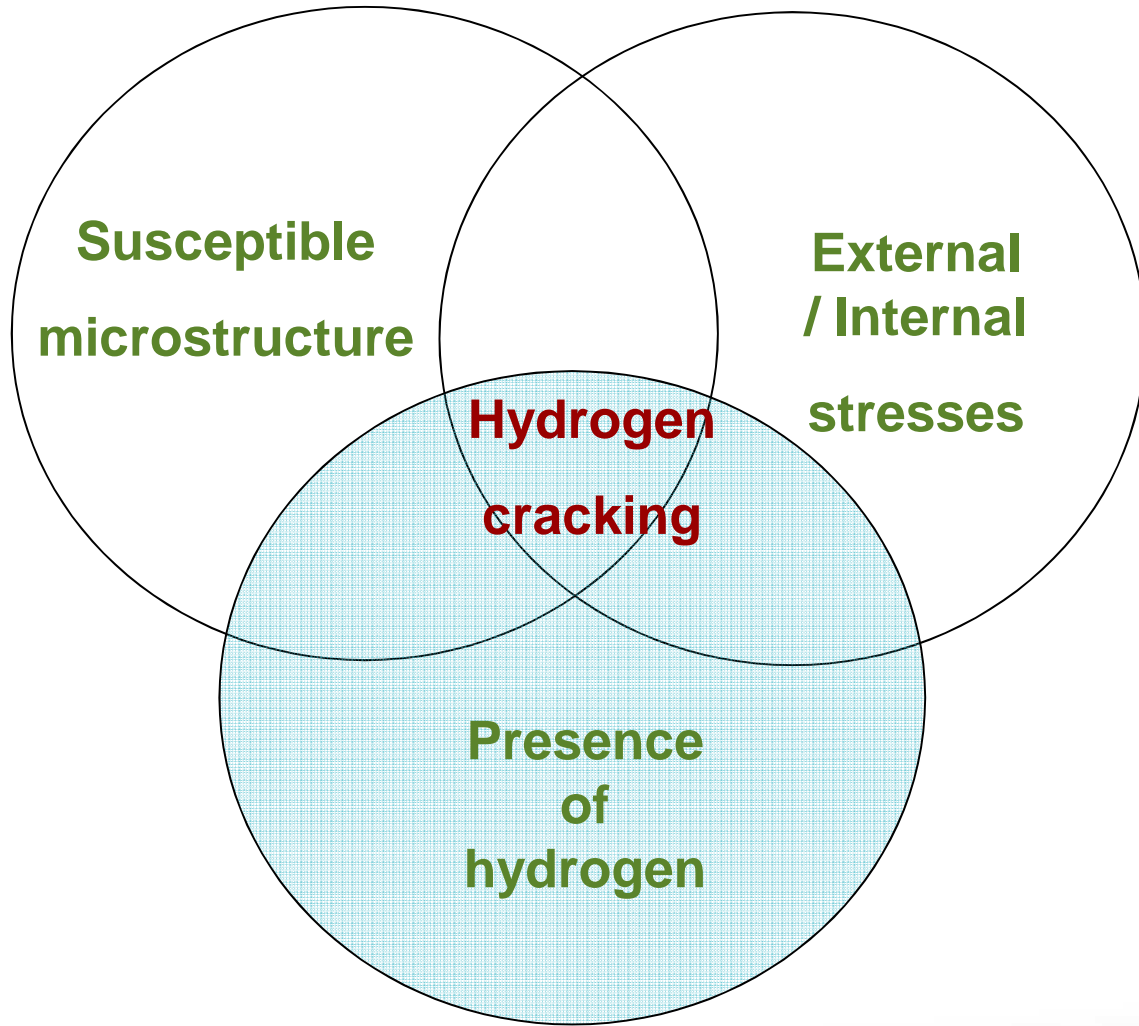

© 2007 – OCAS – All rights reserved for all countries
Cannot be disclosed, used, or reproduced without prior written specific authorization of OCAS
CONFIDENTIAL – Privileged Information – OCAS' proprietary information



Hydrogen embrittlement

Internal hydrogen

Process induced,
linked to:

- Welding process
- Pickling
- Annealing in H₂
- Electro galvanising
- ...

External hydrogen

Materials in hydrogen
applications:

- Gaseous hydrogen
- Corrosive environment

Internal hydrogen

How much H₂ is introduced by the process?

H determination by melt extraction

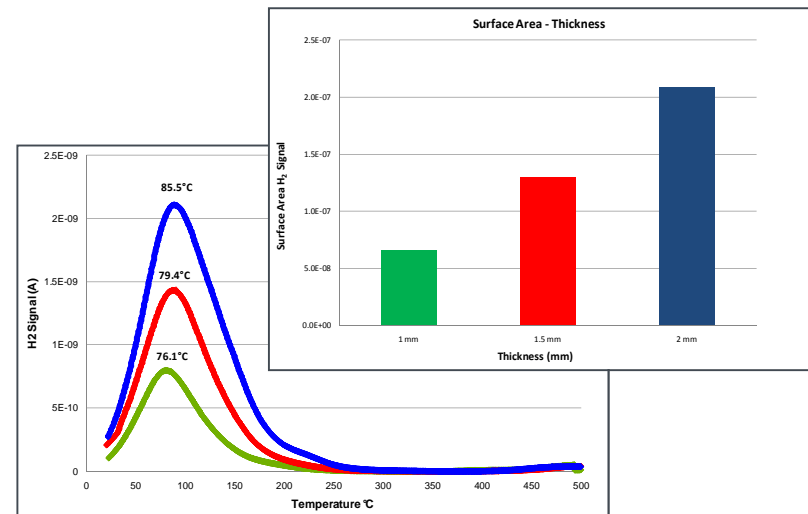
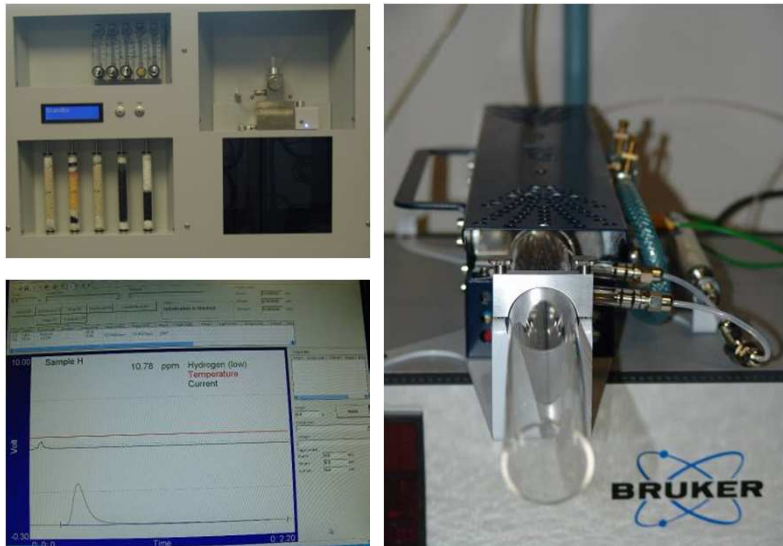

New H-mat for total Hydrogen determination

- Improved accuracy
- Diffusible H-content
- Large samples (~20-30g)

Continuous TDS-methodology improvement

- Effect of sample size & geometry
- Improved vacuum system

© 2007 – OCAS – All rights reserved for all countries
CONFIDENTIAL – Privileged Information – OCAS' proprietary information

External hydrogen

Materials in hydrogen containing environments

Gaseous hydrogen



Corrosive environment



© 2007 – OCAS – All rights reserved for all countries
CONFIDENTIAL – Privileged Information – OCAS' proprietary information

Gaseous hydrogen environment

How do we evaluate the sensitivity of materials?

Gaseous hydrogen at high pressure

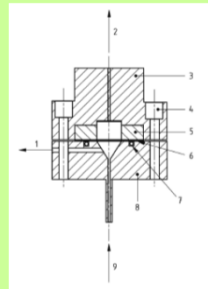
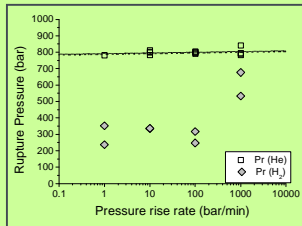

Disc rupture test

Electrochemical in-situ charging

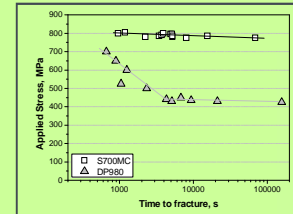

Tensile testing

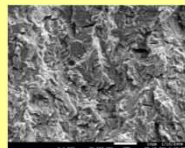
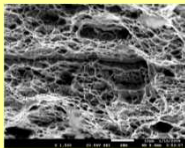

Fractography (SEM & EBSD)

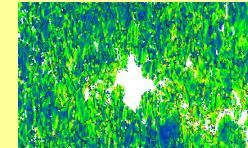

© 2007 – OCAS – All rights reserved for all countries
 Cannot be disclosed, used, or reproduced without prior written specific authorization of OCAS
 CONFIDENTIAL – Privileged Information – OCAS' proprietary information

Corrosive environment

NACE0284 Hydrogen induced cracking

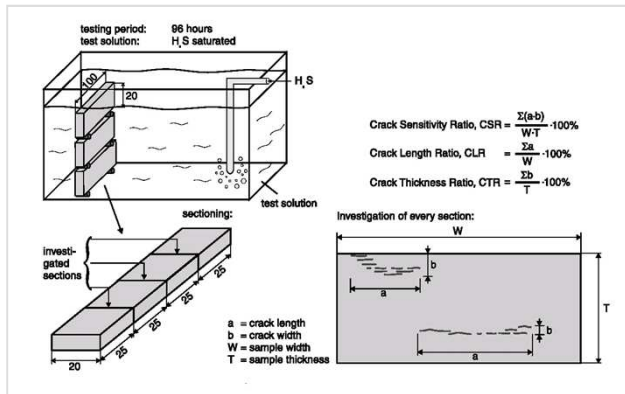

NACE0177 Method B: Bent-beam test

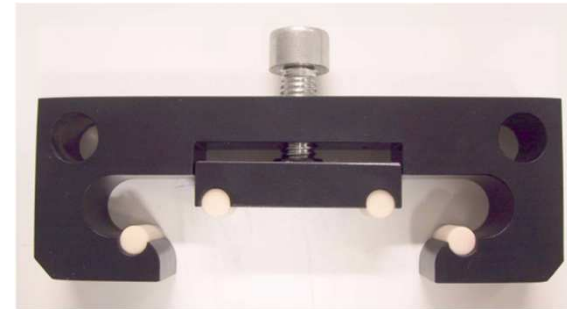

NACE0177 Method A: Constant load testing

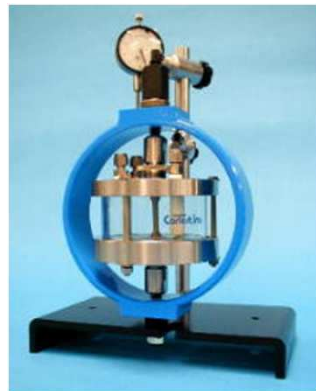

NACE TM-0198 Slow Strain Rate Test (SSRT)



HIC & SSC lab

© 2007 – OCAS – All rights reserved for all countries
 CONFIDENTIAL – Privileged Information – OCAS' proprietary information

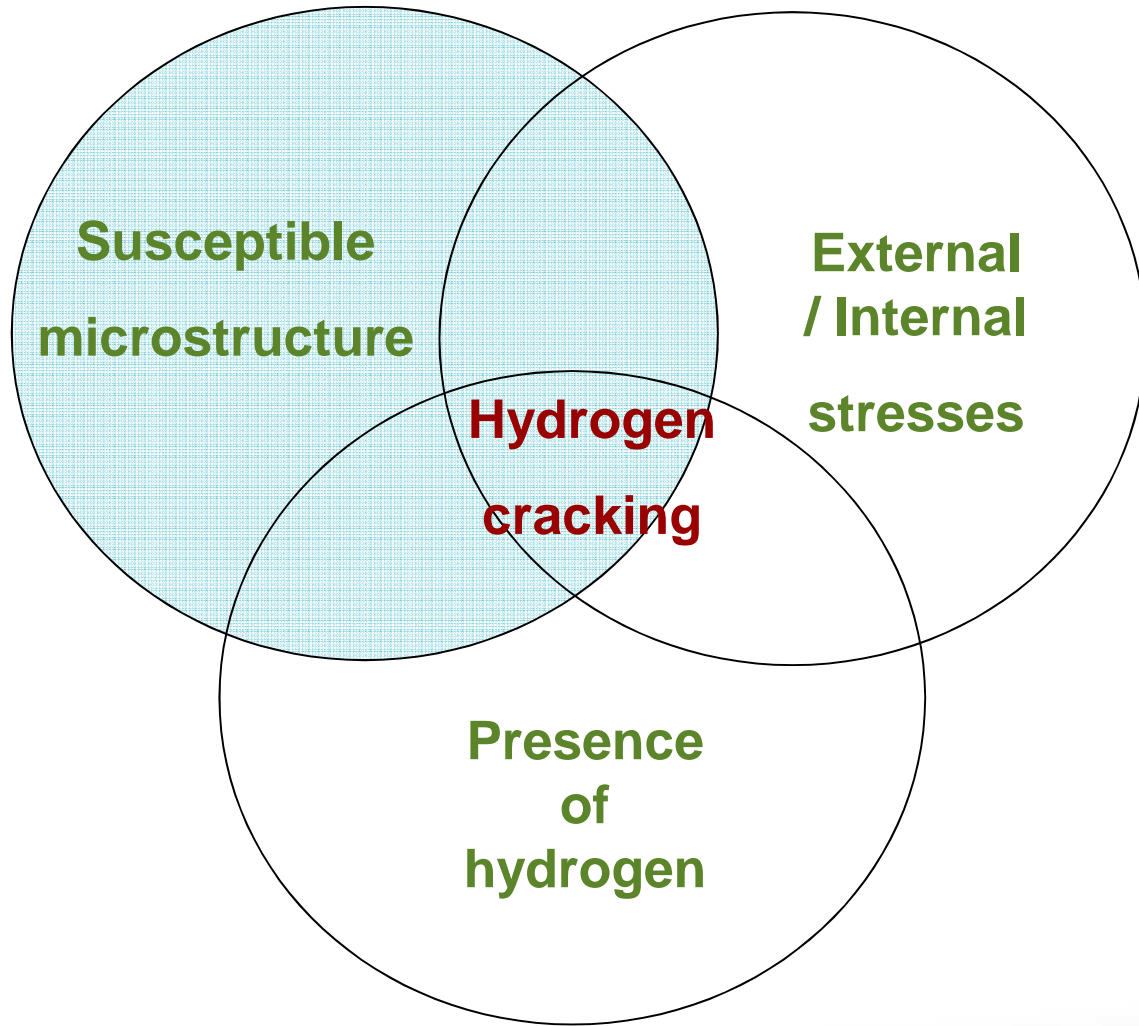

© 2007 – OCAS – All rights reserved for all countries
Cannot be disclosed, used, or reproduced without prior written specific authorization of OCAS
CONFIDENTIAL – Privileged Information – OCAS' proprietary information

Base material

Sensitive microstructure

e.g. High strength material (> 700 MPa)

High alloyed

High thickness



What is the critical H₂ content for HE?

Can we decrease the sensitivity?

Sensitivity of the material

What is the critical H₂ content for HE?

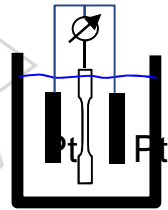

Charge & load

In-situ charging



Slow strain rate

Constant Load

Incremental step

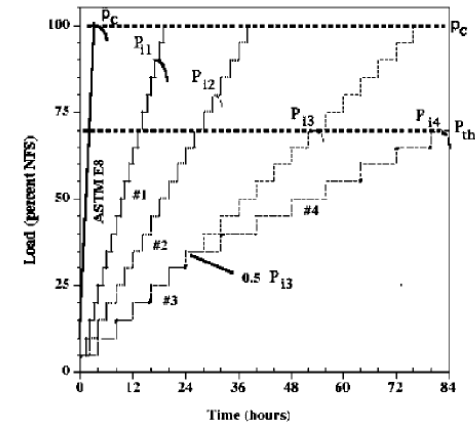
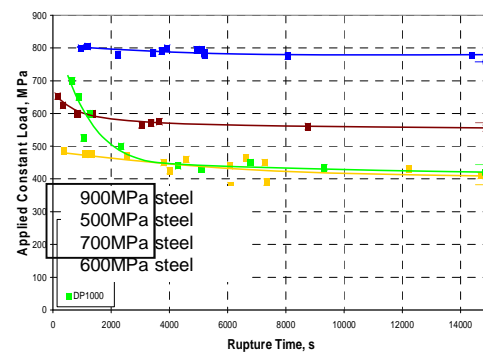
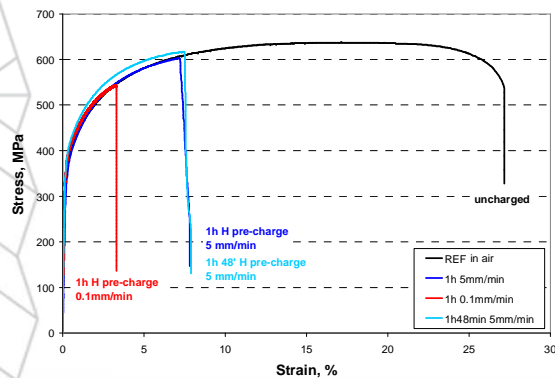

© 2007 – OCAS – All rights reserved for all countries
 Cannot be disclosed, used, or reproduced without prior written authorization of OCAS
 CONFIDENTIAL – Privileged Information – OCAS' proprietary information

Sensitivity of the material

Can we decrease the sensitivity?

Chemical composition

Microstructure

Trapping

Metallurgical processing

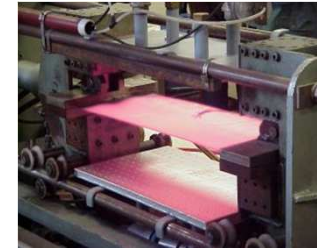

Material characterization

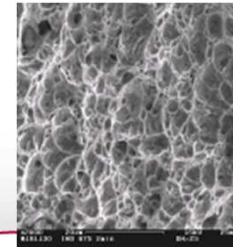
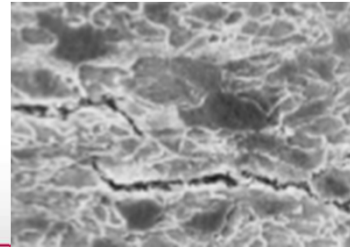
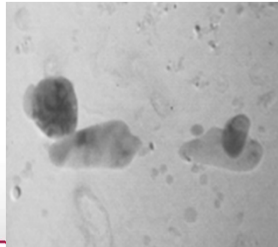

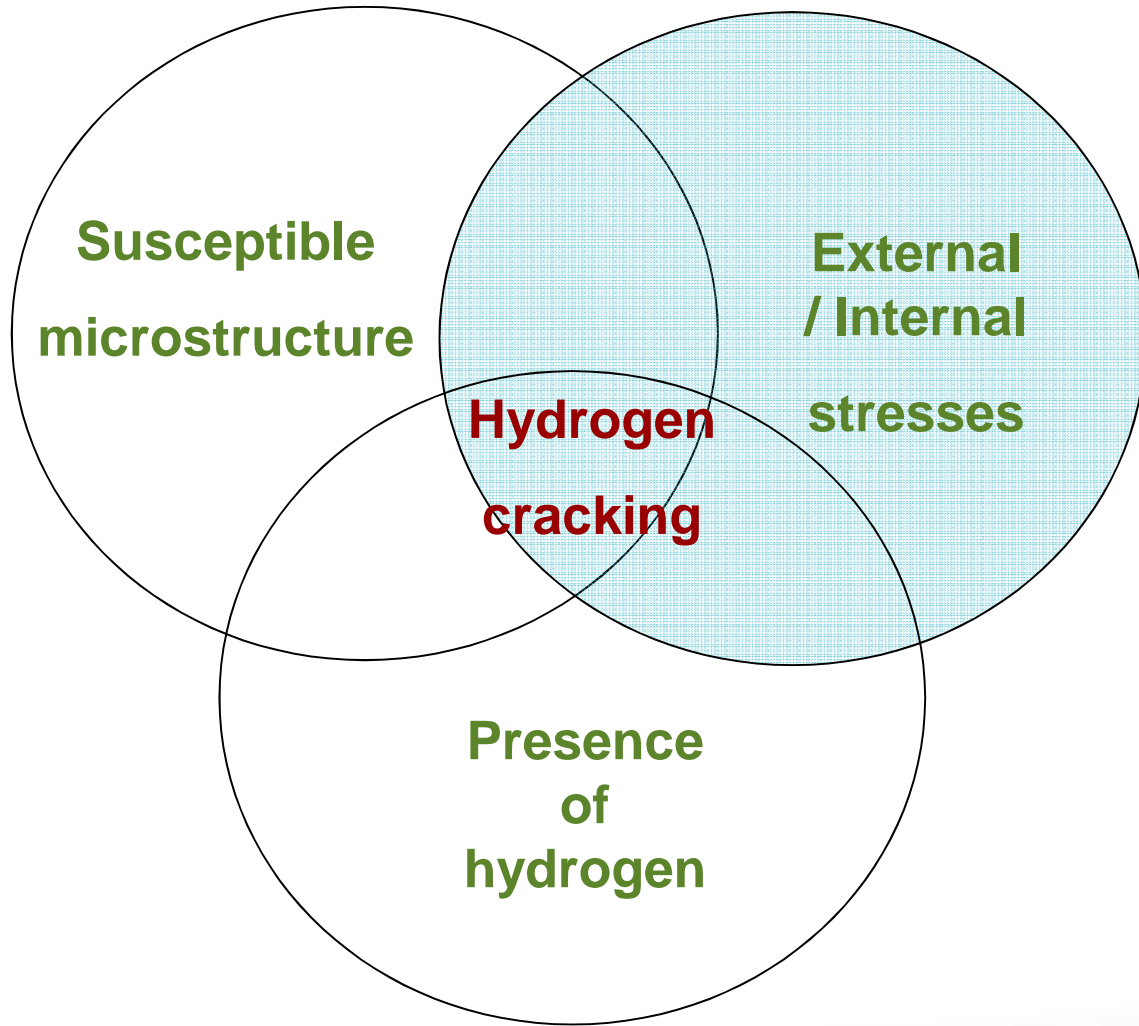

© 2007 – OCAS – All rights reserved for all countries
Cannot be disclosed, used, or reproduced without prior written specific authorization of OCAS
CONFIDENTIAL – Privileged Information – OCAS' proprietary information

Internal / external stresses

How to avoid stresses?

Process

- **Forming, fatigue and joining** simulations
- Optimisation of **customers' processes**

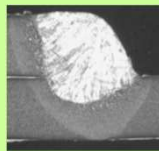

Application

- **Weight or cost reduction** thanks to innovative product design and smart materials selection
- Rapid **prototyping** & production of small series

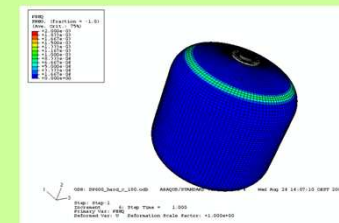

Hydrogen related activities at OCAS

- **Methodology and Competence Building**
- **Product Development Support**
- **General Research**
- **Collaborations**

Examples of collaborations

- Development of a new steel grade for ultra high strength bolts
 - H-embrittlement sensitivity by constant load testing currently ongoing
- Study of IHE in beams
 - Influence of cleanliness by Constant load testing with in-situ charging and Slow strain rate testing with pre-charging
- Select suitable high strength steel to produce large tanks (1 m³) for high pressure hydrogen storage
 - The Disc Pressure Test following the standard ISO 11114-4 Method A is used.
- Reduced lifetime of bearings
 - Hydrogen pick-up was demonstrated & Material analysis and quality control performed
- Hydrogen embrittlement study of Titanium alloys in very pure hydrogen environment
 - What is the critical temperature for this HE?
- Evaluation of 3 different steel grades
 - TDS and permeation study for
 - Assessment of relative diffusible hydrogen
 - Identification of trapped states
 - Measurement of diffusion coefficients